

54"/60" H Gondola Endcap Slatwall

Copyright © 2018 DGS Retail
(800) 211-9646 Press 1

READ BEFORE ASSEMBLING OR USING SHELVING

This basic instruction sheet is supplied by DGS Retail as a reference guide only. Please read complete Lozier Assembly Instructions that can be found online at:

http://www.lozier.com/wp-content/uploads/InstallationInstructions/Basic_Shelving.pdf

- The online Lozier assembly instructions and safety information should be reviewed with all store personnel, and along with all other instructions for Lozier products, must be preserved and provided to any subsequent user or purchaser of these fixtures. Additional copies available upon request.
- Install all shelving according to installation instructions and use components only as instructed. Shelving and components should only be installed or rearranged by trained personnel who have read and understand these instructions and warnings.
- Local codes and regulations concerning building, fire, sanitation, or seismic requirements may apply to some installations. It is the responsibility of the owner of these fixtures to check with local building authorities to determine what codes or regulations, if any, apply and always install the shelving in compliance with any such requirements.
- When installing or rearranging shelving, never move assembled shelving.
- Do not combine Lozier products with non-Lozier products.
- Never use damaged parts. Damaged parts may cause shelving to be structurally unsafe or create exposure to sharp or pointed edges. If parts were damaged in shipment, do not use and contact your Lozier Customer Service Representative. If parts are damaged after shipment, discontinue use immediately and order replacement parts.
- Do not exceed Allowable Load Limits(see pages 3, 5 & 6 or the Lozier Catalog). Make certain you calculate the unbalanced load as shown on pages 5-6 of these instructions. Exceeding allowable loads may cause the shelving to tip over or collapse.
- Base fronts, either open or closed, are required for structural integrity and stability. Use of shelving without base fronts may cause the shelving to collapse. Caution: Use of any shelving without Closed Base Fronts (CBF) may allow material handling or floor cleaning equipment to collide with the Base Brackets causing the shelving to be knocked out of alignment or collapse. All components which require trim such as Uprites (U) and Base Brackets (BB) must be installed with trim pieces. Untrimmed parts may have unfinished edges that must be covered by trim to avoid exposure to store personnel or customers. Use Molding End Trim to cover exposed corners of S-style shelves.
- Do not hang Peg Hooks, Shelves or other accessories on the back side of a Wall Section or any section without Base Brackets. Wall Sections do not have Base Brackets (BB) on the back side to provide support, and use of the back side to display merchandise may cause the section to tip over.
- To avoid store personnel or customers accidentally coming in contact with display fixtures, never allow any Shelf, Peg Hook, or other display to protrude into an aisle or to extend beyond the edge of the Base Deck or End Deck (if used).
- Anchor Base Brackets of all free-standing Wall Sections (those not backed against a building wall or other support) regardless of Uprite height to leveler spacing ratio.
- All End Merchandising Panels intended for use with Shelves or accessories must include End Decks or other floor display to direct people away from the shelves or displays above the End Deck or other floor display.
- When using End Merchandising Panels on a fixture, where the first shelving section behind the EMP is not equipped with shelves that engage into the uprite slots, top rail hold down clips with uprite inserts (Lozier P/N HMA4381) must be installed. Failure to do this could allow the top rail to become disengaged, and the fixture to fall over, causing product damage or personal injury. Do not lean tall or heavy items against shelving unless shelving is anchored to a suitable building wall, to the floor, or is otherwise braced to prevent overturning. The weight and force of leaning items on unanchored or unbraced shelving may cause the shelving to overturn or collapse.
- Shelving (or racks) that are leaning or bending when loaded may indicate a dangerous overload or impending collapse. Loads should be immediately reduced, and the cause for this condition should be corrected, before reloading. Refer to appropriate installation instructions to assure shelving (or racks) are properly assembled, replace any damaged components or parts, and do not exceed recommended maximum loads or engage in any other unsafe use of the shelving (racks).
- Provide safe access to all levels of storage & display shelving in accordance with applicable OSHA regulations. Never allow anyone to climb, walk, or stand on shelving. These shelves were not designed to withstand the extra weight and impact of climbing, walking and standing, and the added weight and impact of such actions may cause the fixture to collapse.
- Never alter, modify or otherwise structurally change the shelving or any of its component parts. Modification or alteration may cause the shelving or component part to become structurally unsafe resulting in tipping, collapse or other failure of the fixture.
- When using an open back system, do not use No-Base Wall End Displays (WEDNB_). Using a WEDNB_ with an open back system will put a side load into the fixture causing it to collapse. Safety Warning WARNING FOR YOUR SAFETY IMPORTANT! Failure to follow these instructions and warnings may result in overturning or collapse of the fixture, resulting in personal injury to your employees or customers, damage to property, or damage to the fixture itself.

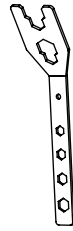
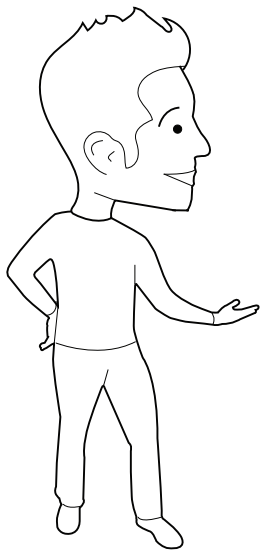

LEVELING
WRENCH
INCLUDED



CARPENTERS LEVEL



RUBBER MALLET

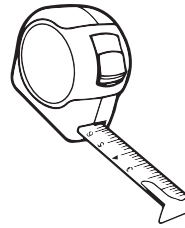

TAPE MEASURE



STEP STOOL

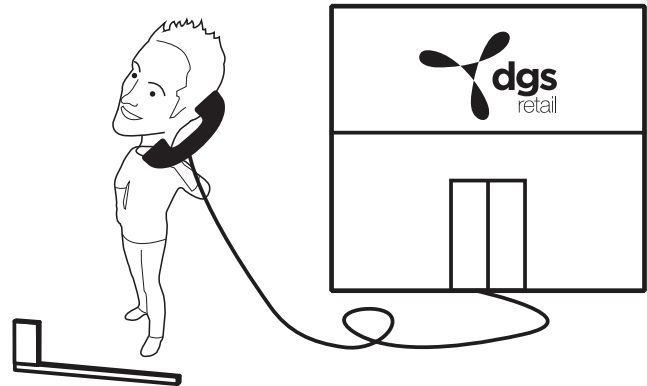
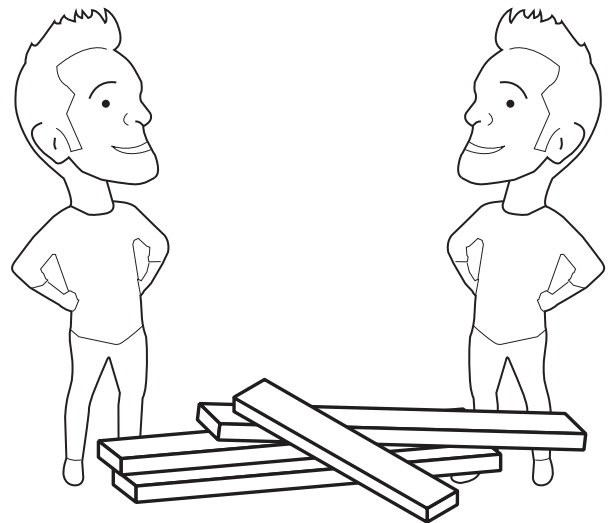
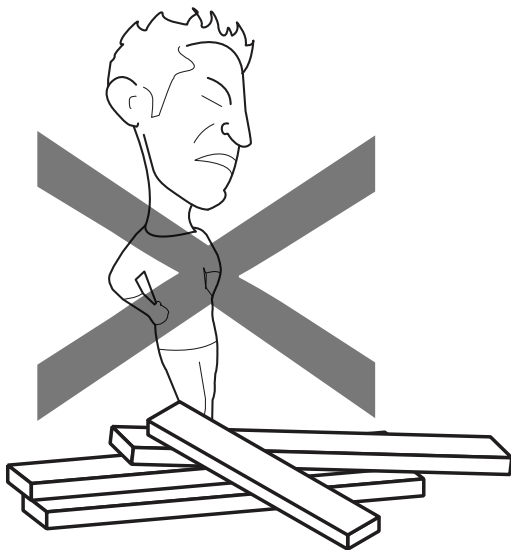

1

Mark the floor with chalk line or tape where display will be set up

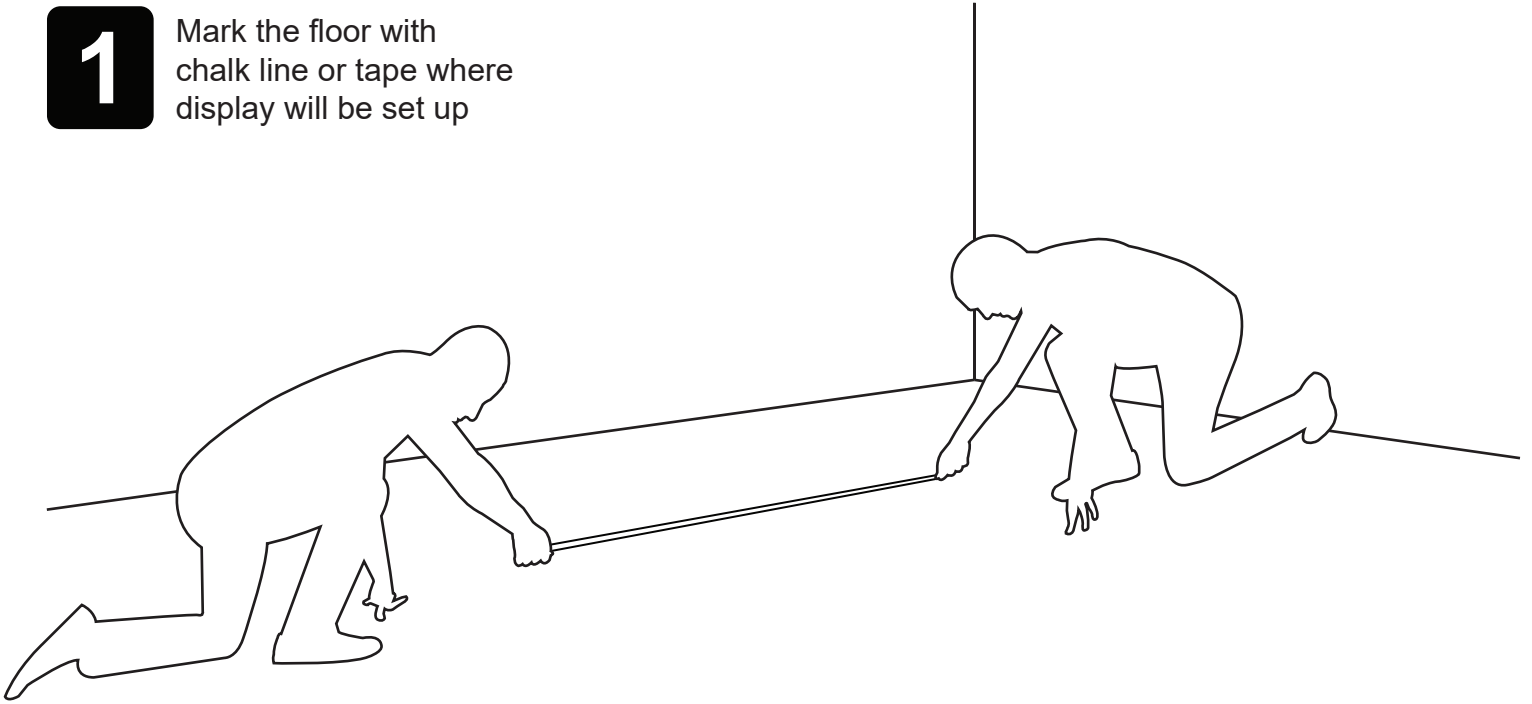

2

Upright
2x

Base
2x

Latch must be engaged for Safety

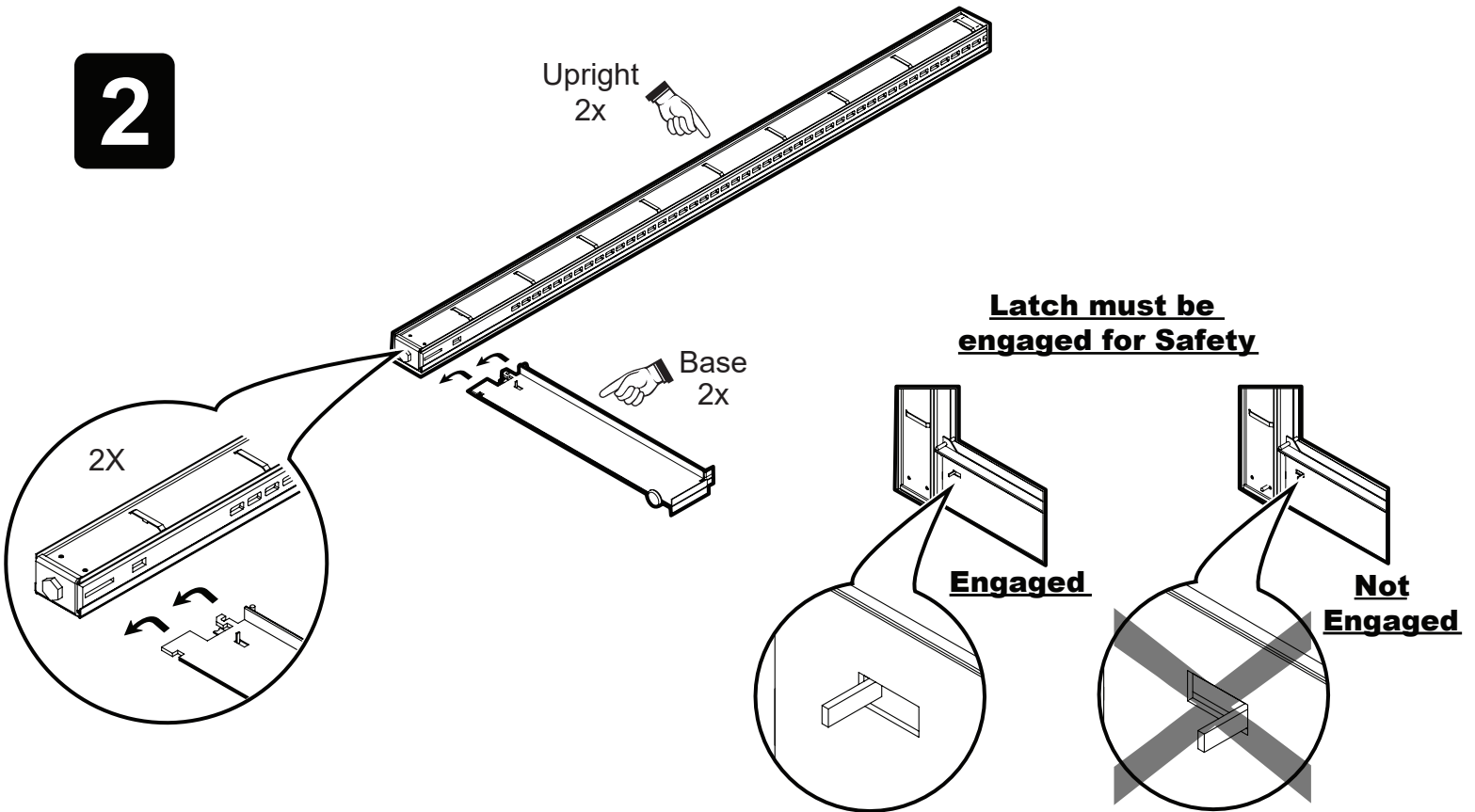

3

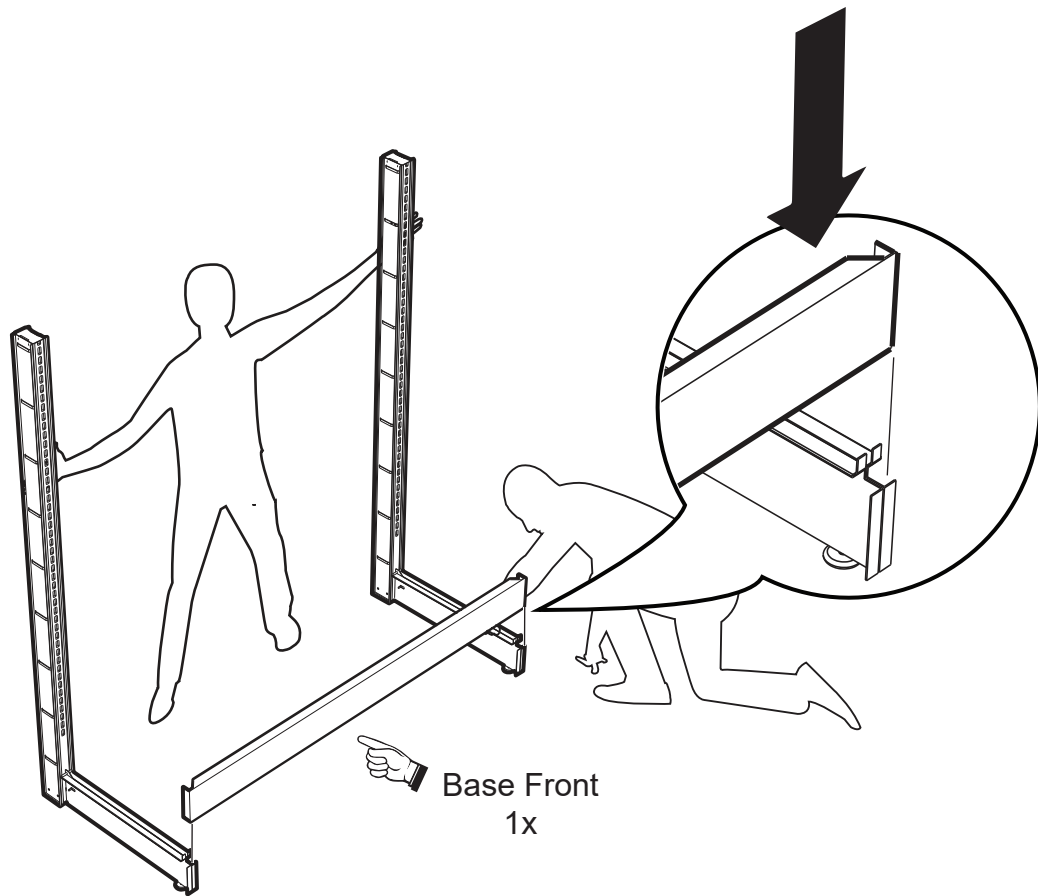

4

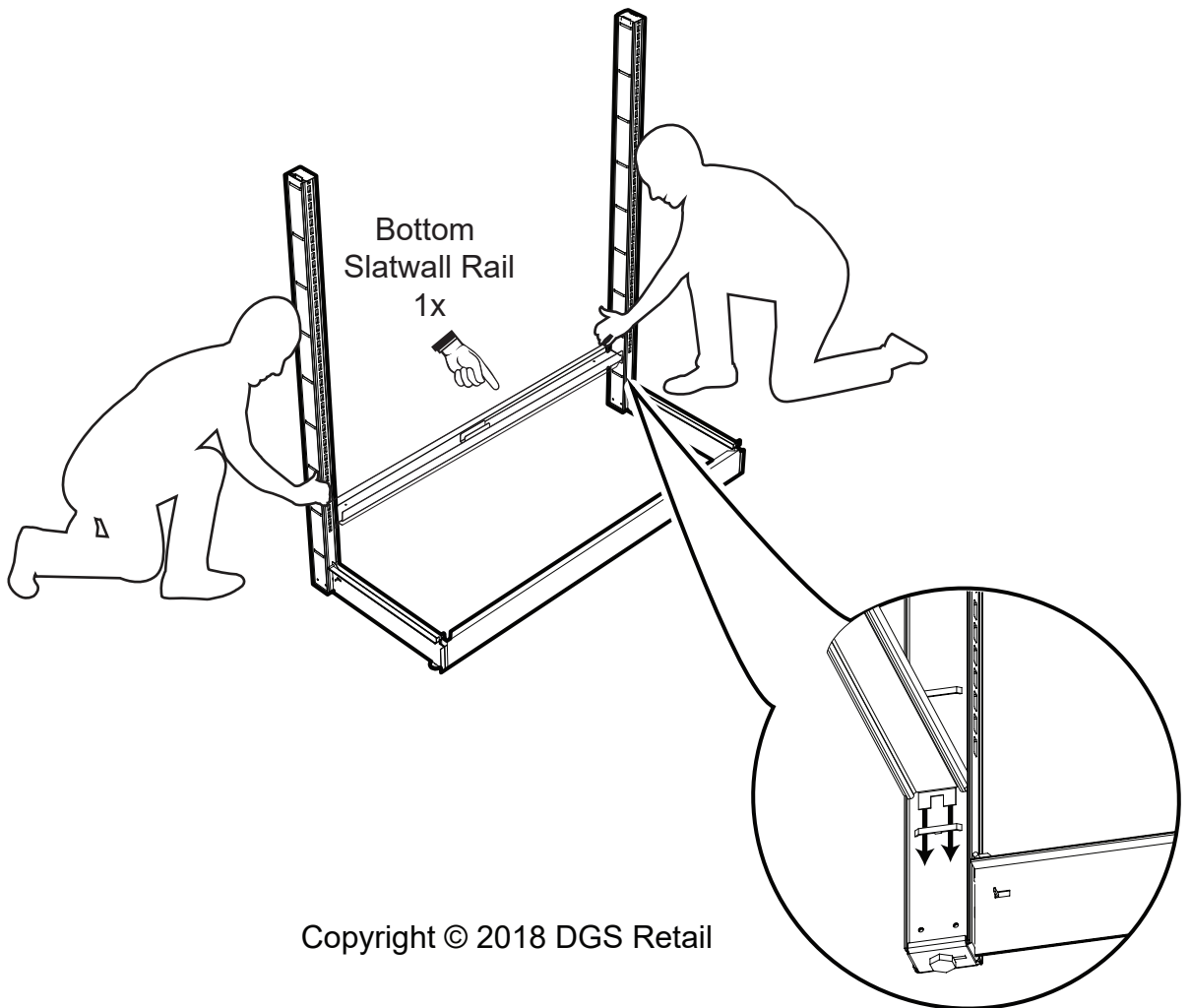

5

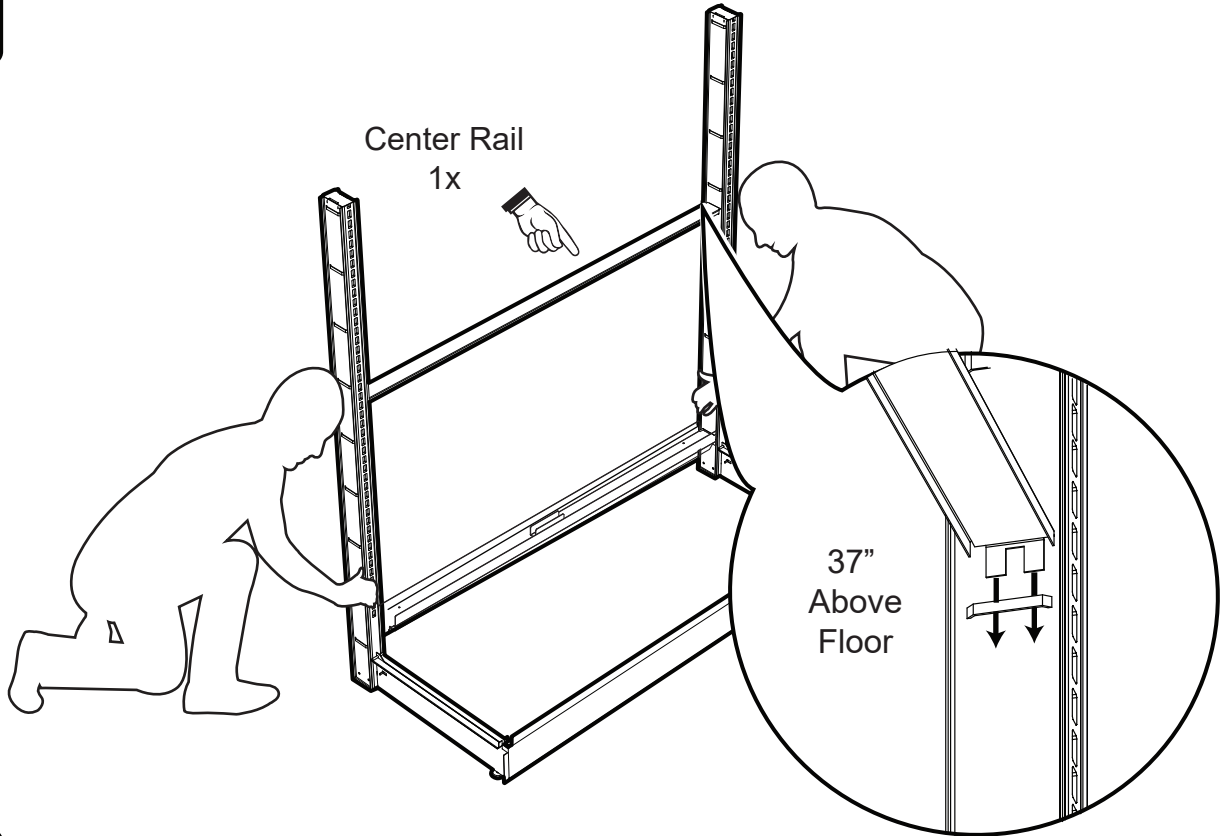

6

Leveling

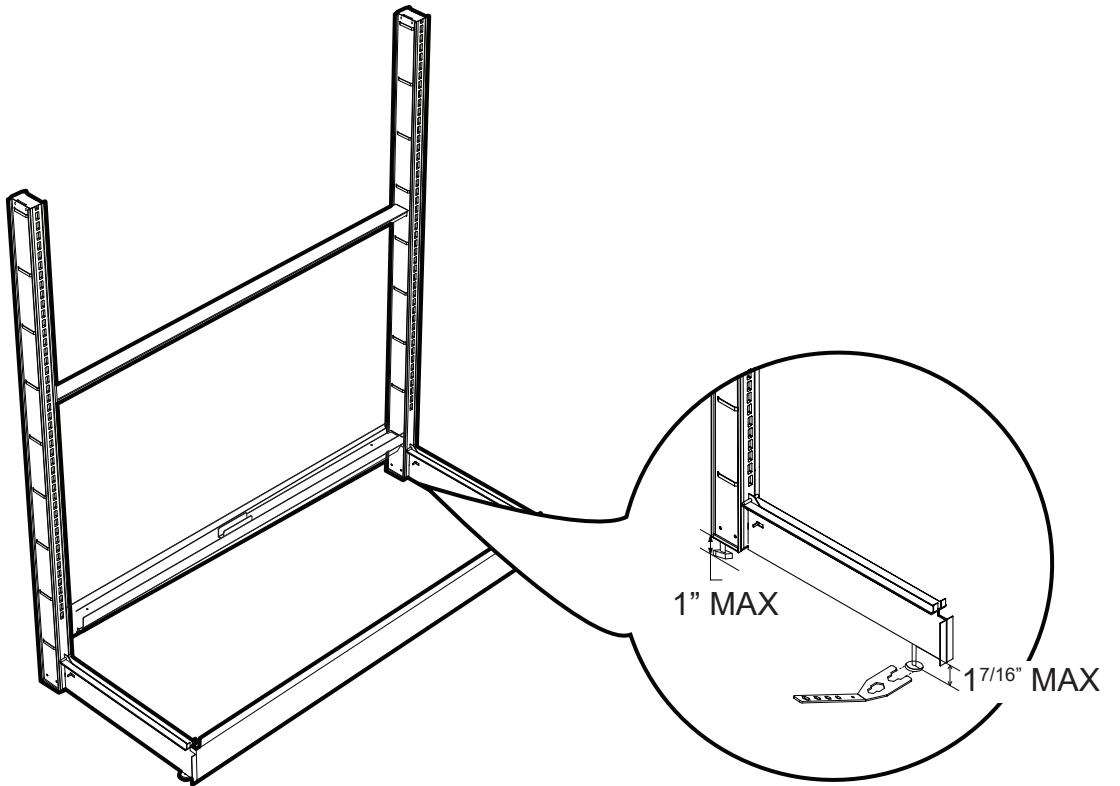
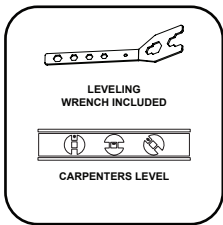

7

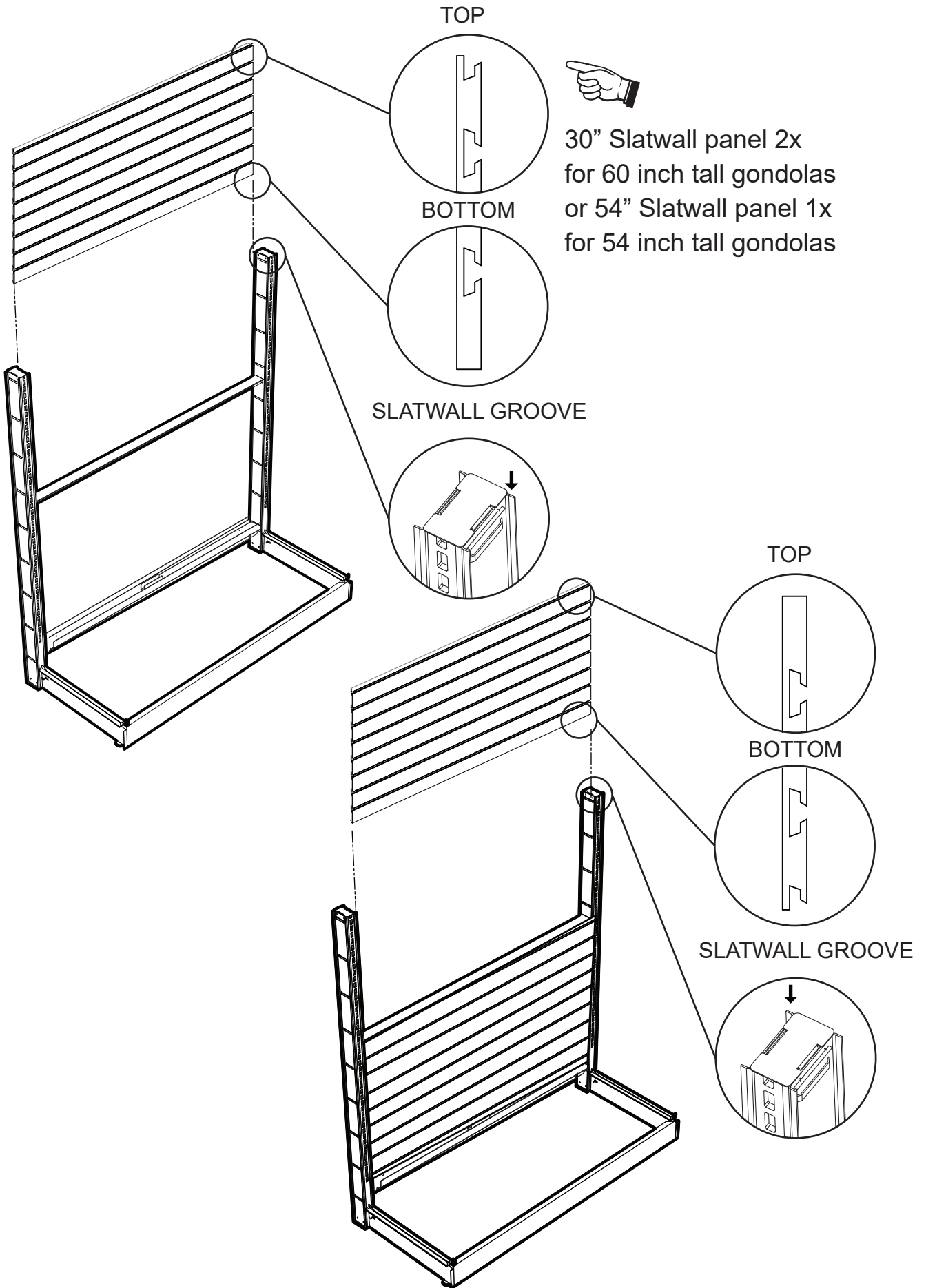

8

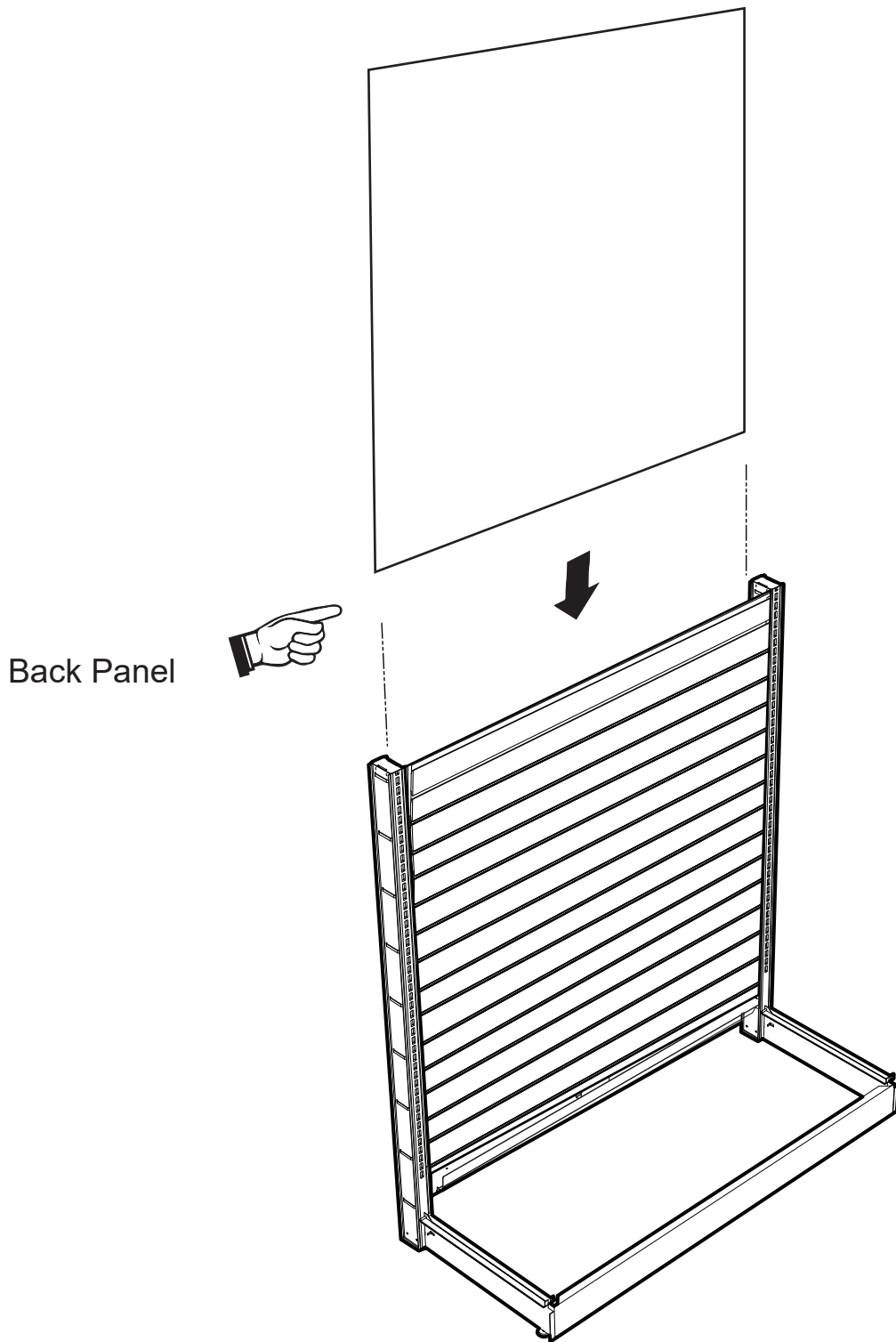

9

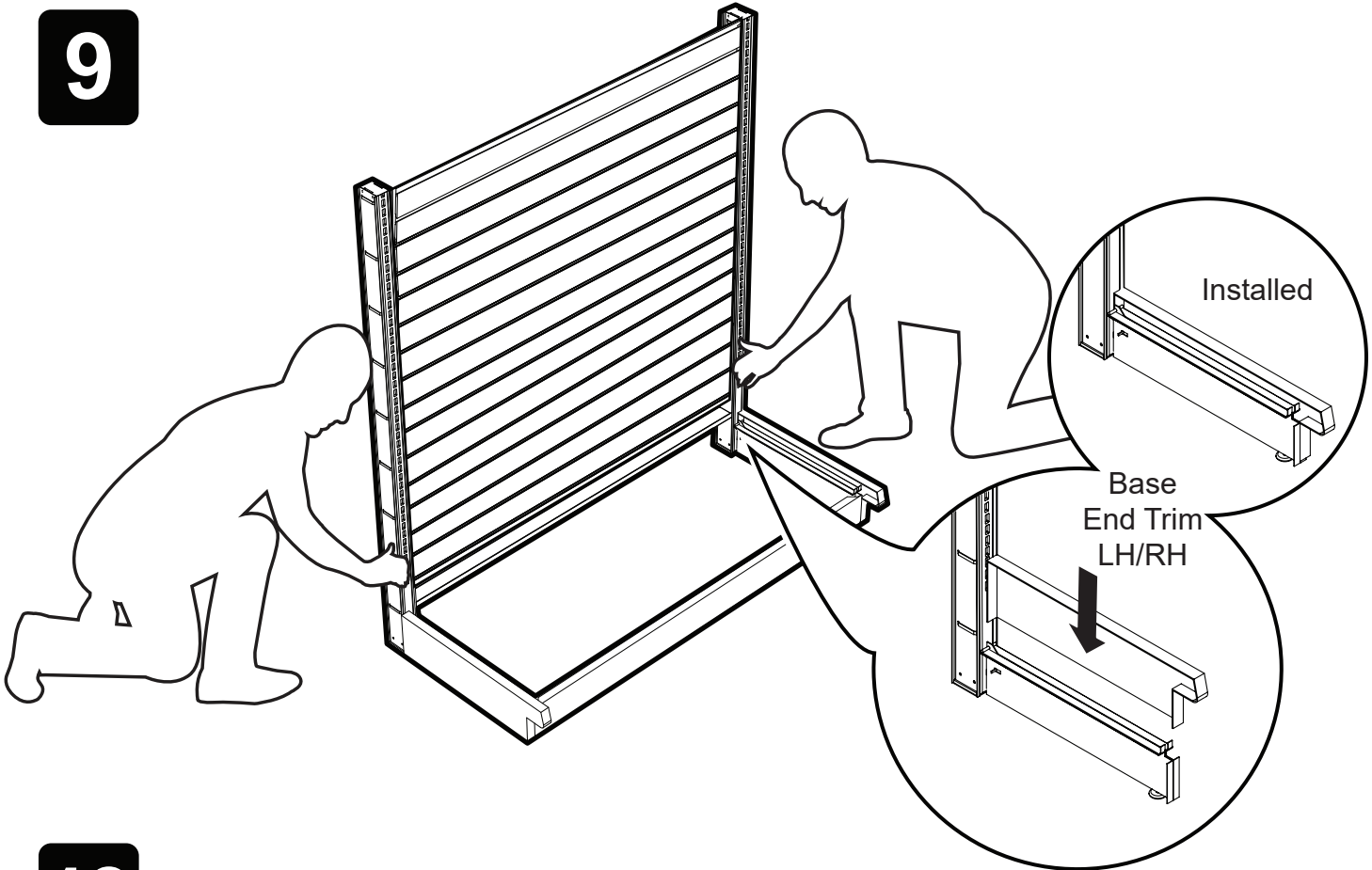

10

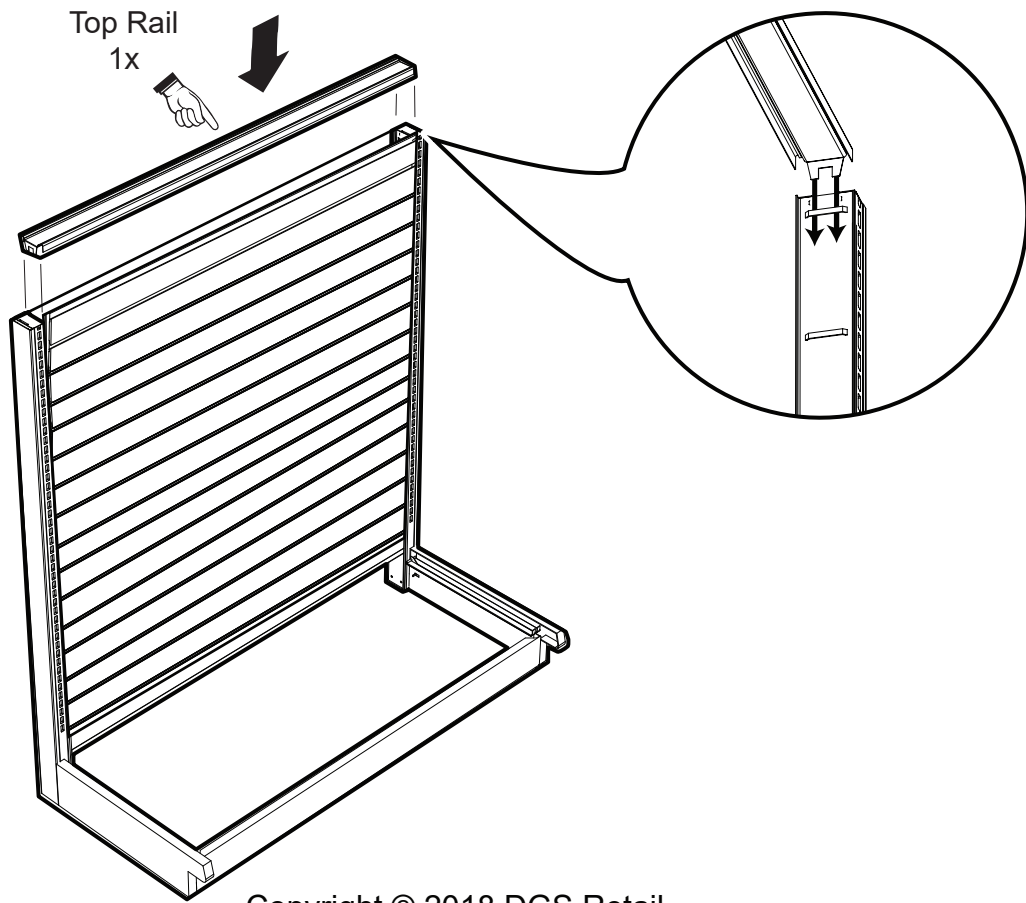

11

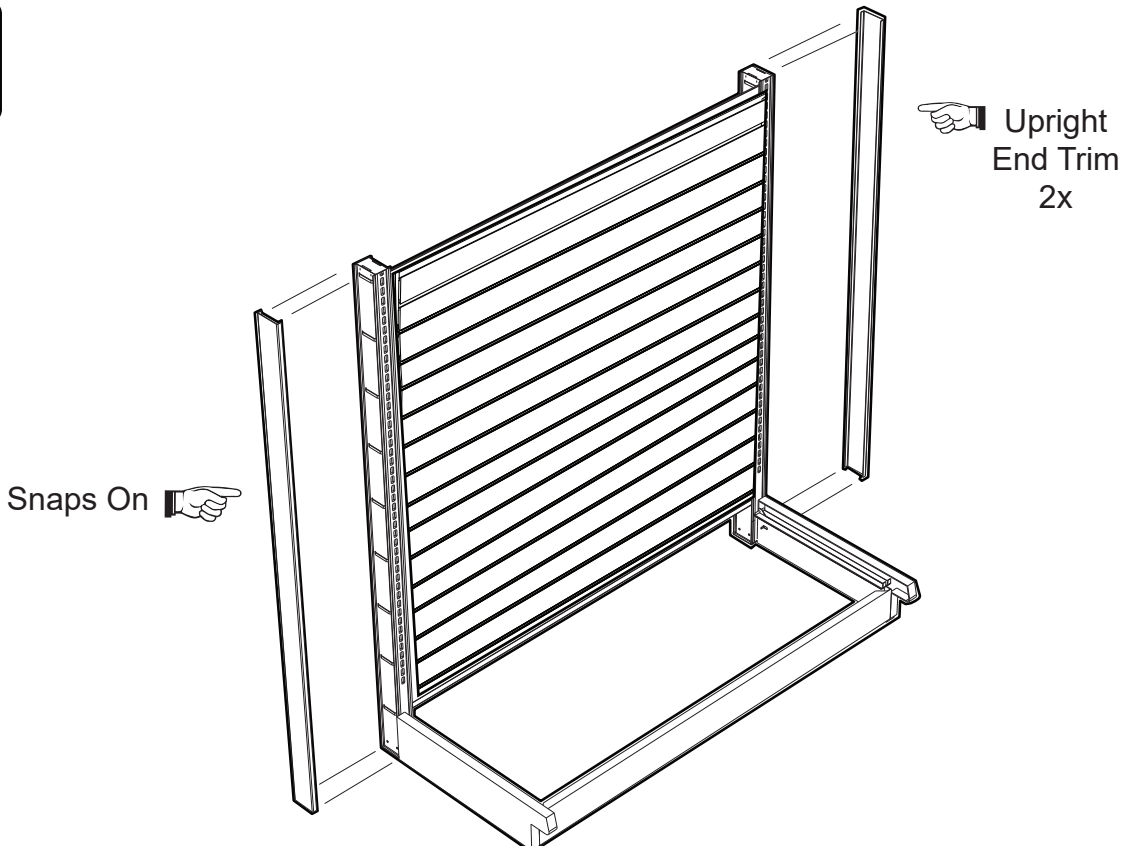

12

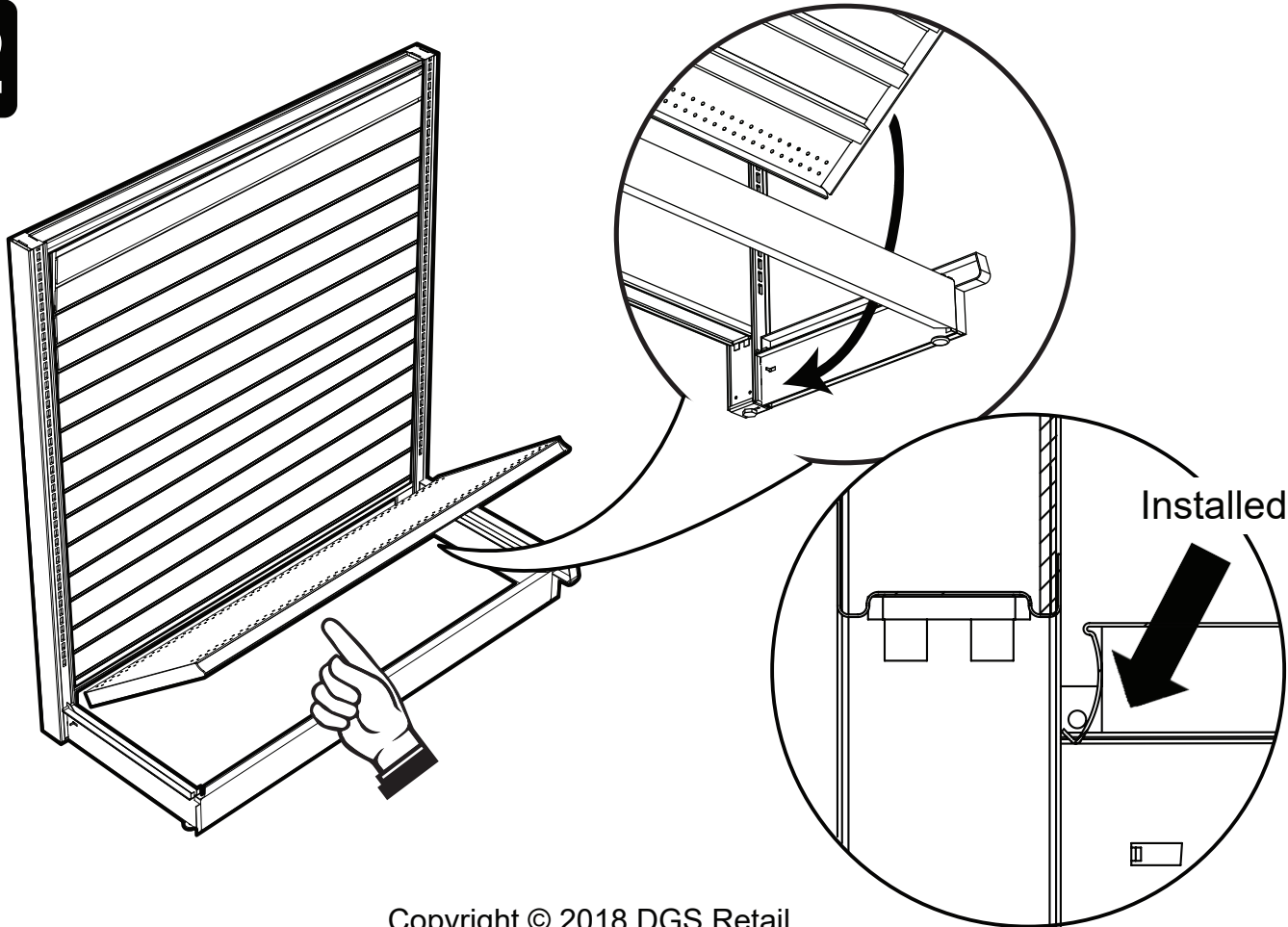

13

